

PANTS FINISHER PF 50

The outstanding performer with industry 4.0 connection



Pressing for Excellence

Cutting edge control technology for a perfect finishing result and process data acquisition for quality assurance.

Your benefits:

- ✓ **VEIT Connectivity:** Industry 4.0 connection enables the exchange of process data with manufacturing and ERP systems
- ✓ **Intuitive touch screen:** All program parameters can be viewed at a glance or changed in a moment
- ✓ **Stretch Control:** Sensitive adjustment for waist size and leg length

New! Optional measuring device for waist size and leg length.

Waistband tensioning device

- Precise adjustment of waistband tensioning force is stored within the finish program
- Extension of size spectrum through 2-dimensional waistband tensioning

Technical data

- Dimensions: l x w x h (mm)
1080 x 1250 x 2140
- Electrical power supply:
Connection voltage 220-230 V / 50 Hz
220-240 V / 60 Hz
- Connected load 1.7 kW
(at standard setting)
- Steam supply:
Connection value 6 bar
Steam / condensate 1/2"
Steam consumption approx. 15 kg/h
- Compressed air connection: 5-8 bar

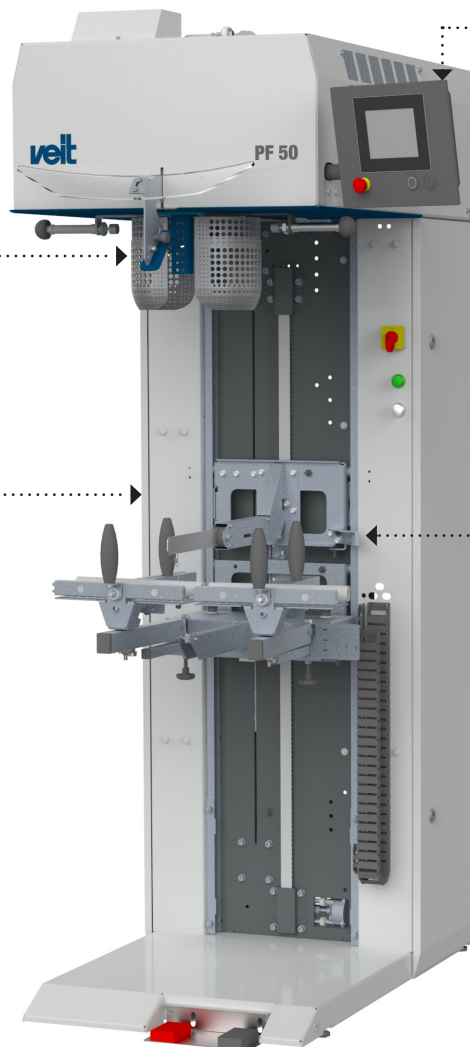

Control panel

- Modern control technology
- New, intuitive operating concept
- Touch screen
- Finish programs can be imported via barcode or RFID scanner

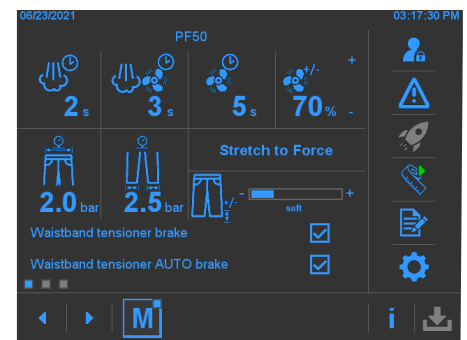

Measuring device (optional)

- Measurement of inseam and waist dimensions during finishing process
- Efficient quality control:
Fast detection of production deviations
Data collection for quality assurance purposes
- Quality assurance through complete data acquisition

We are happy to advise you.

VEIT GmbH | Justus-von-Liebig-Straße 15 | 86899 Landsberg am Lech | Phone: +49 8191 479-100 | E-Mail: info@veit.de | www.veit.de